

# Control and diagnostics of manufacture and maintenance processes of perspective electronic techniques software

D.I. Kardash  
Computer science and information protection  
department  
Ufa state aviation technical university  
Ufa, Russia  
e-mail: kardashdi@narod.ru

A.I. Frid  
Computer science and information protection  
department  
Ufa state aviation technical university  
Ufa, Russia  
e-mail: arkfrid@mail.ru

S.A. Frid  
Computer science and information protection department  
Ufa state aviation technical university  
Ufa, Russia  
e-mail: valex\_69@mail.ru

## Abstract<sup>1</sup>

In the article the analysis of life cycle of modern electronic techniques, a role of maintenance processes and a place of software control and diagnostics in them is resulted. The conception of realization of control and diagnostics of software of electronic techniques manufacture and maintenance processes is offered. The problems of the development of software control and diagnostics processes in order to increase functionality and quality of electronic techniques are formulated.

## 1. Introduction

One of the major factors of the development of modern radio-electronic equipment manufacture plants is the dynamics of scientific, technical and industrial processes of electronic devices and their components creation. Taking into account such dynamics the role of the problems of upgrade of creation and maintenance of electronic production processes increases. In modern conditions life cycle of electronic devices undergoes changes which result to new requirements to the methods of the decision of problems of testing and diagnostics (TaD) of software and configuration information of processes of manufacture and maintenance of electronic techniques (ET). It results to that process of maintenance gets additional functions. So, the role of revealing of the purposes and planning of problems ET hardware and software adaptation to changing operational requirements essentially increases. In the specified conditions of manufacture and maintenance of electronic devices the

value of control and diagnostics of information component of adaptation process grows.

The given paper is devoted to the analysis of TaD status, revealing of the ways of the decision of problems connected with conception and construction of adaptive TaD of information components of perspective TE devices manufacture process.

## 2. The features of modern electronic techniques life cycle

One of modern process of TE manufacture features is - the object of manufacture undergoes permanent updating during manufacture. Modern technologies assume intensive updating production already after its manufacturing, i.e. while maintenance. Thus updating may be represented as production continuation. The most part of time and material expenses is transferred from processes of equipment manufacturing onto processes of information component design. The information component already is considered not only as programming of program-controlled devices (memory of programs, microcontrollers) but as structure configuration of various devices. The special attention is given to tool programming systems.

Now the process of electronic equipment creation is under strong influence of the tendency of programmable (configured) integrated circuits use. Displacement of accent from use of program-controlled microprocessors and microcontrollers onto application of configured integrated technics not simply allows to modernize component TE base and results an essential change of their design and manufacture processes.

Usual processes of microprocessor component base programming transfer on the second plan comparatively

---

Proceedings of the 11<sup>th</sup> international workshop on  
computer science and information technologies  
CSIT'2009, Crete, Greece, 2009

Control and diagnostics of manufacture and maintenance processes of perspective electronic techniques software

processes of integrated devices programming. The source of updating processes is initialized by change of requirements to such devices functional. Design of modern TE occurs to use of prototyping at which there is a consecutive manufacturing and operation of some versions of the products subjected to update. In these conditions the development of application and manufacture of configured component base and the devices created on its basis gets special value.

It is possible to allocate the basic features of modern electronic industry development:

- Reduction of technological norms by component base manufacture (the minimal technological size);
- Increase of integration degree of perspective integrated devices and consequently increase of functional and complication of component base;
- Existence of modern productions in a condition of production prototyping;
- Unification of hardware allowing to increase series of manufacturing, to lower its cost and to increase reliability;
- Complication of production and exploitation software;
- Redistribution of volume and magnitude of functions between software and hardware aside software;
- Increase of expenditures for an information component of development;
- Strengthening the control and diagnostics role both for equipments and software.

Because of necessity of expenses decrease at all stages of life cycle, upgrade, expansion of functions nomenclature and complication of modern component base the increasing loading is shifted on ET software. It allows to realize functional upgrade of a product without modification of hardware [1].

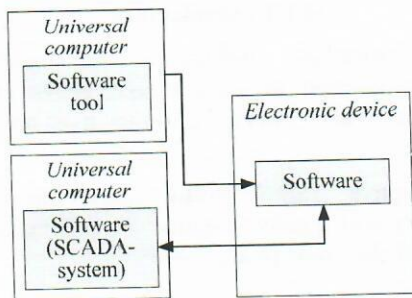

**Fig. 1. Software structure of the calculator with "rigid" hardware structure**

On fig. 1 the structure of industrial purpose TE software constructed on the basis of the calculator with "rigid" hardware structure is shown. Application of configured component base results to growing of the complexity of the resulted structure. The software structure changes in

case of calculators on the basis of configured component base using. The essence of these changes is illustrated on fig. 2.

It is visible that the amount of software types now increases. Besides at modern products there is a new information object - the configuration information.

The TE developer receives an opportunity of creation and updating of the calculator architecture specialized for a solving task. Functional of computing kernel software on configured component base (the block 6 on fig. 2) and its command system could be changed according to specialization of hardware. Thus there is a need of TaD algorithms adaptation in reply to computing kernel change.

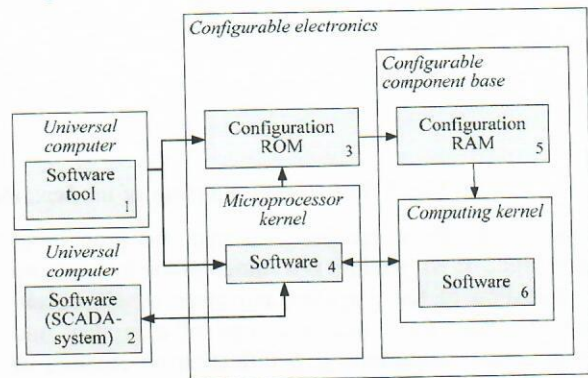

**Fig. 2. Software structure of the calculator with configured hardware structure**

At the further reduction of technological norms the share of expenses for the software and information technologies will grow. The similar tendency is characteristic not only for process of creation of modern component base but also for ET as a whole. Practice of creation of modern electronic systems is more and more declined to creation of systems on crystal - System on Chip (SoC) when all management device is realized as a uniform integrated microcircuit with a minimum of external devices.

Expansion of ET functionalities and increase of complexity of its component base causes complication of algorithms of designing and functioning of electronic devices. Frequently efficiency of algorithms cannot be proved theoretically or is completely confirmed in a course of tests.

In these conditions the problem of effective maintenance could be solved on the bases of operative updating of ET functioning algorithms at all stages of life cycle of a product. In turn, complication of integrated circuits results in complication of mathematical description and software both of TE design and maintenance processes.

Process of ET creation and operation on the basis of configured component base is illustrated on fig. 3.

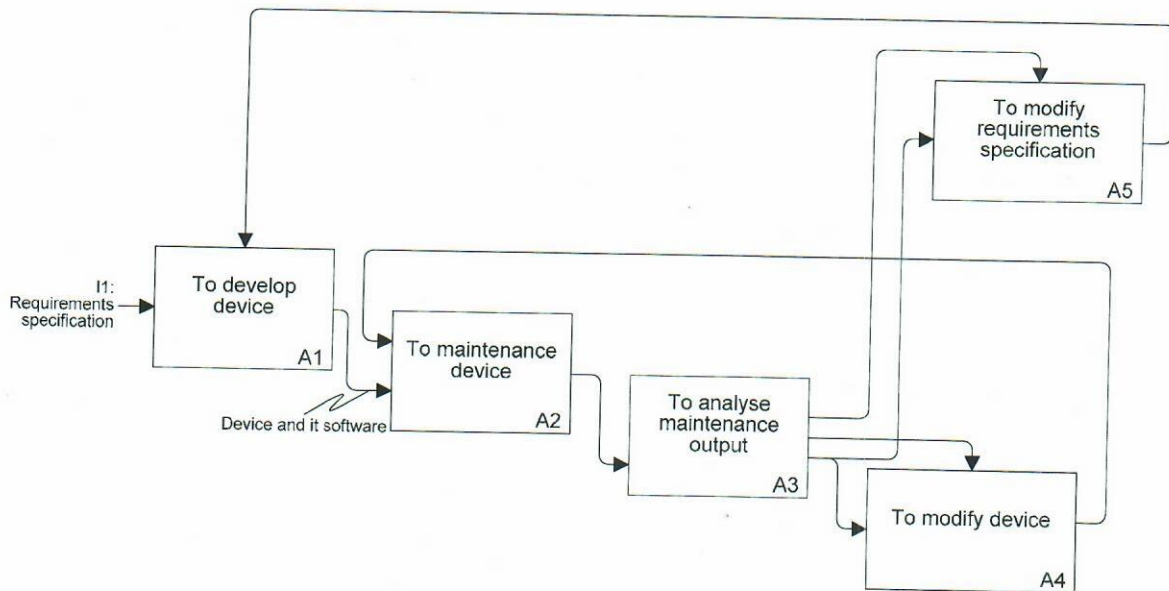

**Fig. 3. Functional diagram of modern electronic techniques creation and operation**

Peculiarity of these processes is that the process of maintenance of ET product is a source of the information for allocation of the purposes and tasks of subsequent adaptation both for a concrete copy of a product and upgrade of the requirement specification on creation of the following variant of a product.

Thus, TaD software processes of creation and maintenance of modern electronic devices leave on the foreground. The relative importance of similar processes for hardware goes down because of their dependences on an information component.

### 3. The conception of adaptive control and diagnostics software design

So, the process of ET manufacture gets adaptive character. Its structure (fig. 4) assumes that requirements specification on design, managerial process by adaptation and operation of prototypes are under the influence of permanent changing external requirements.

In order to realize adaptive process of ET manufacture and maintenance the conception of adaptive control and diagnostics software design for perspective ET devices is offered.

The basic comprehension of given conception is *the adaptive production process* which is carrying out under *permanent* influence of changing *external requirements* of different character (marketing, technical, technological, organizational and so on). Under influence of these requirements there is a permanent *adaptation* of requirements specification, designing and *adaptation of ET prototype, adaptation of production processes*. One of the general part of adaptive production process is *adaptive TaD* (ATaD) which conceptual structure is shown on fig. 5.

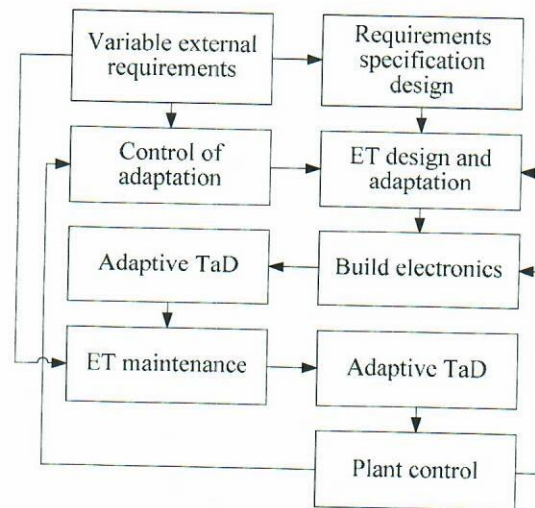

**Fig. 4. Structure of adaptive process of ET manufacture**

The TaD procedures fulfilling in the conditions of adaptive production are carried out above changing objects (first of all - programs), so they must be adaptive themselves.

Using adaptive TaD software allows to increase functionality and quality manufacture and maintenance processes of electronic production.

### 4. A place of control and diagnostics processes during maintenance of electronic techniques

Because of amount of types software of modern ET increases (fig. 2) character of TaD procedures changes too. On fig. 6 there are shown structure and interrelations

of information components of maintenance process (A2 on fig. 3).

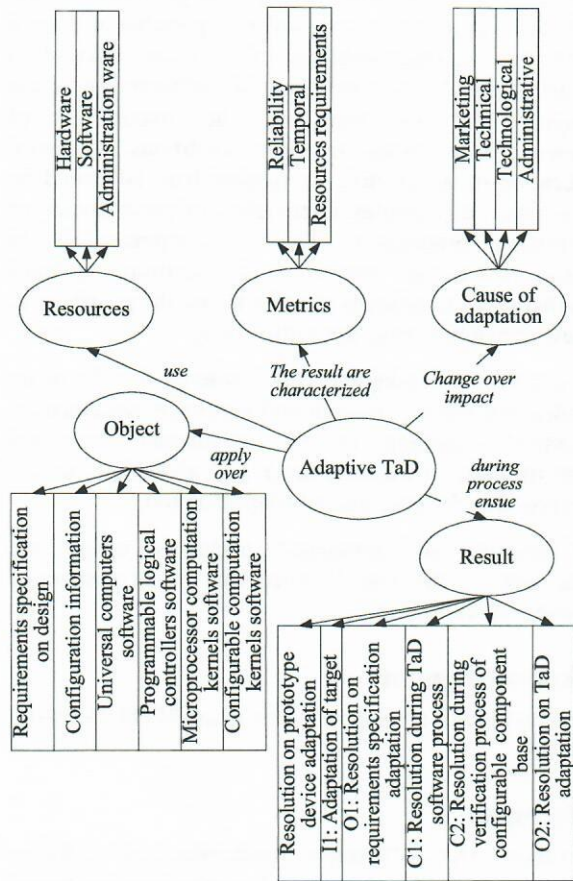

Fig. 5. The conception of adaptive TaD

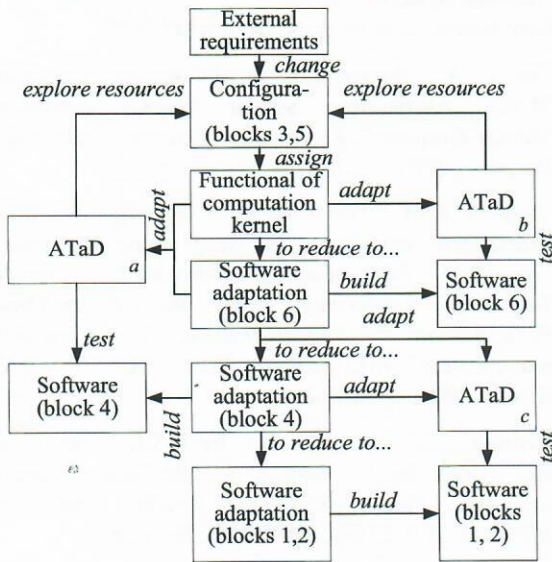

Fig. 6. Structure and interrelations of information components of ET maintenance process

In general ATaD process consists of three components distinguished from each other by TaD objects and the reasons of adaptation (a, b, c on fig. 3). On the figure programmable logic devise (PLD) functional verification

processes and super large scale integration circuit verification (SLSIC) topology are not shown since these characteristics are not programs.

In modern conditions property of integrated approach of verification is considered as a pledge of the decision of many problems of component base development [2]. This conclusion is fair and for TaD software processes both during manufacture and maintenance ET. Similarly, the selected types of software TaD should be connected in uniform system as among themselves and with TaD (verification) of hardware.

Circulating during ET devices production and maintenance information and material objects are diverse and polysemantic, and creation of complex techniques will demand use of new approaches to testing and ways of tests generation. Thus complexity both software and hardware production and maintenance steadily grows that results in growth of brought malfunctions probability. Increasing of information component in described processes requires special attention to the decision of TaD software problems. Absence or an insufficient level of integrated TaD processes is considered now as one of general reasons braking modern hi-tech equipment development.

### 5. Problems of perspective researches

In order to increase ET functionality and quality it is necessary to formulate the problems of perspective researches laying within the framework of the offered conception of adaptive TaD software.

It is possible to formulate the next requirements to TaD processes: adaptive character of execution; comprehensible complexity of test base and temporal efficiency of their application; integrated approach to carrying out TaD software agreed to methodology of hardware verification; the account of interference of a hardware and program component of ET devices.

The set of electronic devices (at use of prototyping) manufacture processes is illustrated on fig. 7. In figure numbers select the areas corresponding to elements of TaD software conception which development allows to increase functionality and quality of production.

Thus the following problems should be solved:

1. Development of the technique for definition of updating software purposes;
2. Development of adaptive algorithms complex of TaD software working under changing conditions of manufacture, operation, high complexity and reconfiguration of calculator component base;
3. Development of the technique for the coordination of equipment verification processes with adaptive TaD algorithms;

4. Development of the technique for adaptive testing software on a target platform and algorithms of automatic generation of test examples base (positions of the given technique are stated in [3] and are protected by the patent for the complex invention [4]);
5. Development of the system for organizational management of adaptive TaD of information maintenance in updating conditions (the example of such system for software development is represented in [5]).

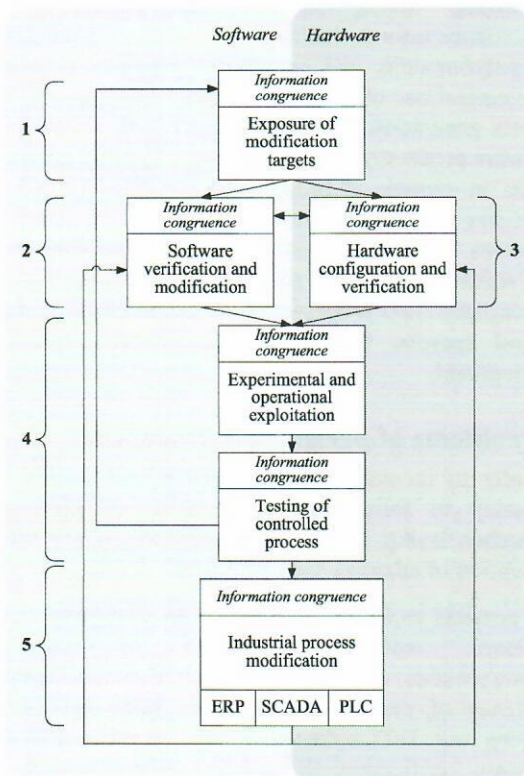

**Fig. 7. The set of electronic techniques manufacture processes**

As the general problem for all specified problems within the framework of the offered conception it is possible to specify the necessity of information coordination of diverse TaD processes with each other. In particular the complex approach to the decision of described problems will allow to carry out TaD software processes of perspective devices ET manufacture and maintenance satisfying specified requirements.

## 6. Conclusion

The level of modern development of computer facilities and wide use of its various variants constructed on the basis of program management determines the necessity

of design technologies and testing of programs development. Considering managing and specialized software of microcontrollers, programmed logic controllers, systems on a crystal it is possible to draw a conclusion that the problems of TaD are exposed to intrinsic upgrade in conditions of software life cycle changing and increasing of the importance of maintenance processes. In these conditions successful application of perspective component base is braked by the absence of complex approaches to performance of supervising procedures. Their development should outstrip the further perfection of electronic technics manufacturing techniques in order to use the possibilities of new component base most effectively.

The conception of adaptive TaD is offered. It is based on the idea that during program and hardware maintenance, dynamical changing of ET calculators functional (adapting under a concrete task) TaD algorithms should be exposed to the coordinated adaptation too.

The decision of formulated problems within the framework of the stated conception is a perspective direction of researches.

## Acknowledgments

These researches are supported by grant RFBR № 08-08-00357.

## References

1. Ivanov D.V. "Modern principles of software construction of onboard and overground hardware-software complexes". Open Society "Corporation "Russian Systems", 2006. <http://www.rusys.ru/docs/Den/article.pdf>.
2. Lohov A., Rabovoljuk A. "Complex functional SLSIC verification. System Questa companies Mentor Graphics". *Electronics: Science, Technology, Business*, 2007; 3: 102-109.
3. Skrjabin A.M. "The method of the organization of specialized calculator software dynamic testing process". In: *Proc. of the 2d All-Russia Scientific and Technical Conference with the International Participation "Mechatronics, automation, management" (MAU'2005)*, Vol. 2. USATU, Ufa, Russia, 2005, pp. 281-287.
4. Skrjabin A.M., Kardash D.I, Frid A.I. "The device and a way for the testing of calculator managing program". Patent №2300795 Russian Federation, MPK7 G 05 B 23/00.; 2007, bull. № 16, p. 9.
5. Skrjabin A.M. "Fuzzy expert system of managing software estimation". In: *Proc. of the Post-graduate student and the competitor*, Vol. 3. USATU, Ufa, Russia, 2008, pp. 137-140.